

# EM-410

## Lavalier Microphone



### DESCRIPTION

The TOA EM-410 is designed with a focus on clear, accurate voice reproduction with maximum intelligibility, making it ideal for such applications as lectures and religious services. It is equipped with an electret condenser microphone element that has a hypercardioid pickup pattern, and which rejects undesirable off-axis sound, to minimize potential feedback. The EM-410 is designed to prevent sound degradation when it is attached at the chest, so as to cut noise and ensure optimal performance. The microphone's capsule rotates 360 degrees, allowing the best possible pickup angle, according to where the microphone is worn.

### FEATURES

- Ideal for voice-oriented applications such as lectures, presentations and religious services.
- Compact electret condenser microphone element with hypercardioid pattern for highly focused pickup.
- Designed for best performance when attached to the chest area.
- The cable holder minimizes noise from cable and clothes rustling.
- Capsule rotates 360 degrees, for optimal pickup even when worn on a lapel.
- Phantom power range of 9 to 52 volts enhances operational versatility.

### APPEARANCE AND DIMENSIONAL DIAGRAM

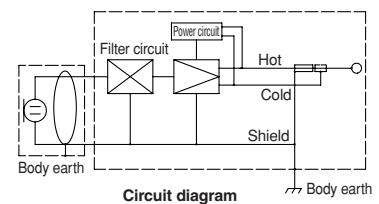
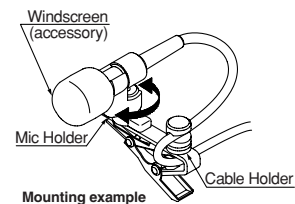
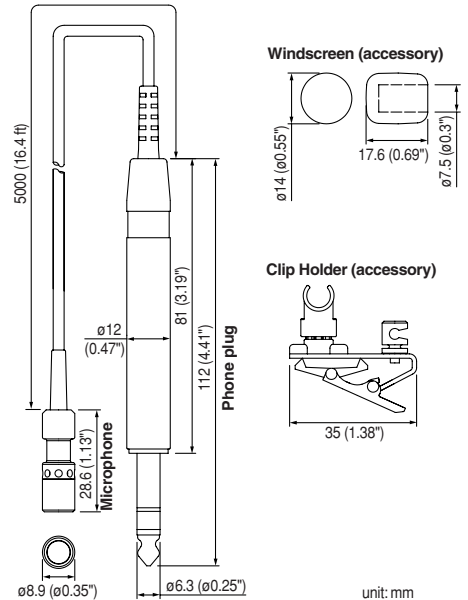

## SPECIFICATIONS

<b>Element</b>	Electret condenser
<b>Polar Pattern</b>	Hypercardioid
<b>Rated Impedance</b>	120Ω, balanced
<b>Rated Sensitivity</b>	-47dB (1kHz 0dB = 1V/Pa)
<b>Phantom Power</b>	9 – 52V DC
<b>Frequency Response</b>	100Hz – 15kHz
<b>Output Connector</b>	Blanced-phone plug
<b>Cable Length</b>	5.0m (16.4 ft)
<b>Operating Temperature</b>	0°C to +40°C (32°F to 104°F)
<b>Finish</b>	Body: Copper alloy, black, semi-gloss, paint
<b>Dimensions</b>	ø8.9 × 28.6mm (ø0.35" × 1.13") (cord excluded)
<b>Weight</b>	100g (0.22 lb)
<b>Accessory</b>	Windscreen × 1, Clip Holder × 1

## CHARACTERISTIC DIAGRAMS

**Frequency Response**

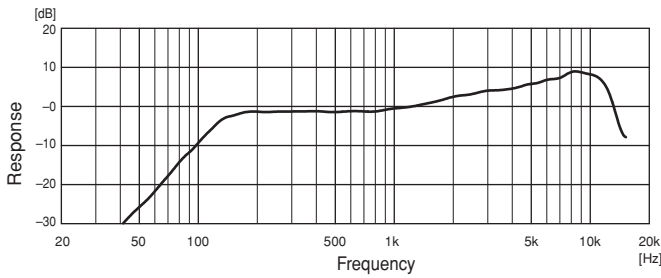

**Polar Response**

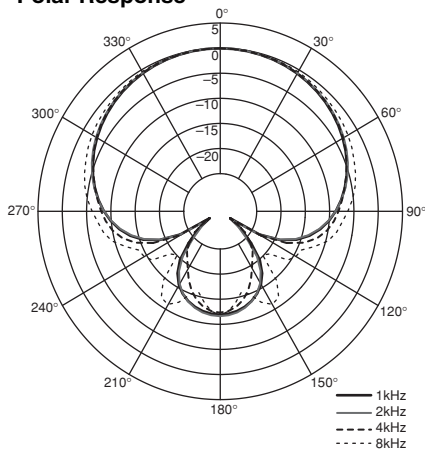

## ARCHITECTURAL AND ENGINEERING SPECIFICATIONS

The lightweight miniature lavalier microphone shall be able to be clipped to a shirt or jacket, and shall have a hypercardioid electret condenser microphone element, for highly focused pickup and rejection of off-axis sound. The microphone shall be designed for best performance when it is attached at the chest. The microphone capsule shall rotate 360°, to enable the best possible pickup angle when worn on a lapel. Frequency response shall be 100 Hz to 15 kHz. Rated impedance shall be 120 Ω, balanced, and rated sensitivity shall be -47 dB (1 kHz 0 dB=1 V/Pa). The microphone shall be powered by any phantom power source supplying 9 – 52 volts.

The output connector shall be a balanced-phone plug, and cable length shall be 5.0 m (16.4 ft). Operating temperature shall be 0° C to +40° C (32° F to 104° F). Body finish shall be copper alloy, with black semi-gloss paint. Dimensions shall be ø8.9 × 28.6 mm (ø0.35" × 1.13") (cord excluded), and weight shall be 100 g (0.22 lb). A windscreen and a clip holder shall be provided as accessories. With clear and accurate voice reproduction, the microphone shall be suited for such applications as lectures and religious services.

The lavalier microphone shall be TOA model EM-410.